

# Starrett®

Precision, Quality, Innovation

METROLOGY SYSTEMS

## THE HE400

Vision Systems

Vision Inspection Systems

Optical Comparators

Software



# HORIZONTAL BENCH OPTICAL COMPARATOR

## HE400

The most economical of our bench top comparators, the HE400 offers a 16" (400mm) diameter screen, X-Y stage travel, bayonet-style interchangeable lenses and Q-axis angular readout: all to improve capacity and performance. These latest horizontal comparators are fitted with either MetLogix™ M1 or M2 measuring software or Quadra-Chek® digital readout systems as standard, making them simple to use, but having the power to satisfy the most complex measuring requirements.

### OPERATOR INTERFACE

Feature	MetLogix™		Quadra-Chek®	
	M1	M2	QC121	QC221
Mounted to comparator arm	x	x	x	x
Color graphics	x	x		
Touch screen operation	x	x		
MS Windows® operating system	x	x		
X-Y-Q axis digital readout	x	x	x	x
2D geometry software with skew	x	x	x	x
Optical edge detection option	x	x		x
Software developer	MetLogix™	MetLogix™	Metronics/Heidenhain	Metronics/Heidenhain



### SPECIFICATIONS

HE400	
Horizontal Travel	10" (250mm)
Vertical Travel	4" (100mm)
Focus Travel	1-1/8" (28mm)
Top Plate*	18.9" x 4.7" (480 x 120mm)
Image	Inverted and reversed

\*With machined single slot for easy fixturing



## FEATURES AND SPECIFICATIONS

- All metal construction
- Single bayonet-style lens mounting system
- Collimating condenser with yellow/green filter and provision to mount further accessories
- Linear encoder (glass scale) on both X and Y axes
- LED profile and surface illumination
- Fully retractable flexible duplex fiber optic surface illumination
- Digital protractor for accurate angle measurement 1' resolution
- Available with MetLogix™ M1 tablet, M2 PC-based touch screen measuring software or Quadra-Chek® digital readout system
- Fine adjustment on all axes
- Quick mechanism on the X-axis

## OPTIONS

- Six interchangeable fixed magnification lenses including 10x, 20x, 31.25x, 50x and 100x
- Canopy and curtains (designed to mount on cabinet stand)
- Purpose built cabinet stand
- Extensive line of accessories

## HE400 DIMENSIONS

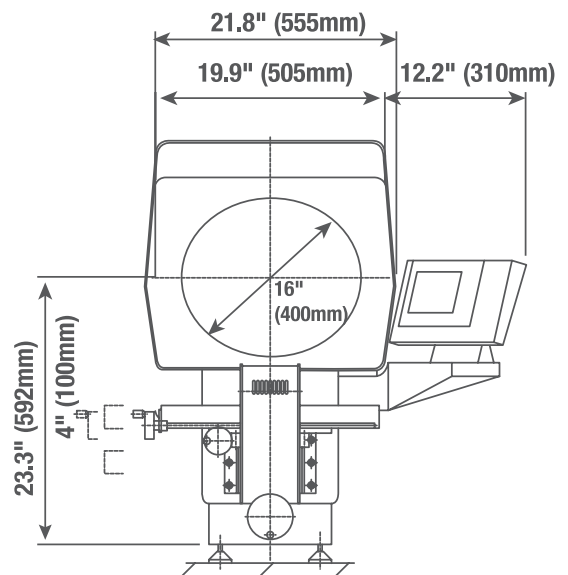
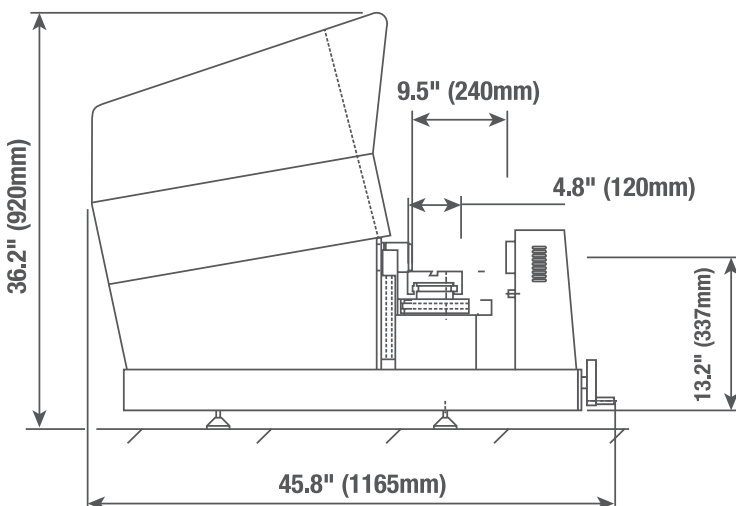

### WEIGHT AND DIMENSIONS

	HE400
Net Weight	230lbs 105kg
Gross Weight	300lbs 135kg
Shipping Dimensions	49" (L) x 32" (W) x 51" (H)

## STARRETT PRODUCT LINES

Band Saw Blades

Force Measurement

Material Test

Jobsite & Workshop Tools

Laser Measurement

Metrology Equipment

Precision Granite

Precision Ground Solutions

Precision Measuring Tools

PTA & Hand Tools

Roundness Measurement

Service

Webber Gage Blocks

# METROLOGY SYSTEMS



Follow us!



starrett.com

Catalog 81

Metrology Systems

01/16

5M/TP

The L.S. Starrett Company 2015© Specifications subject to change.

# Starrett®

Phone: (978) 249-3551 | Fax: (978) 249-8495  
121 Crescent Street-Athol, MA 01331-1915-USA